

Wiring Diagram

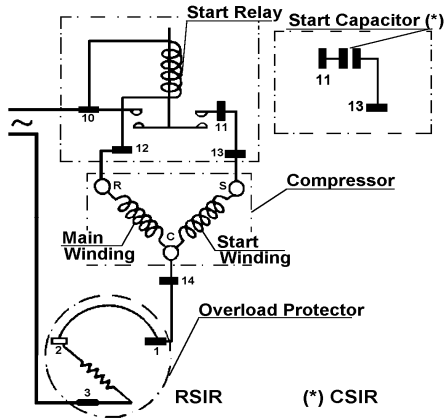

Compressor Terminals

- C = Common
- R = Run
- S = Start

Electrical components are supplied unassembled. Use of components other than specified will void warranty.

Dimensions (inches)

A: 7.93" B: 6.8" C: 8.02" D: 4.0" E: 6.5"

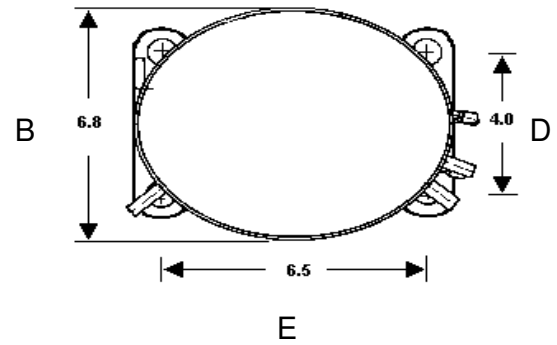
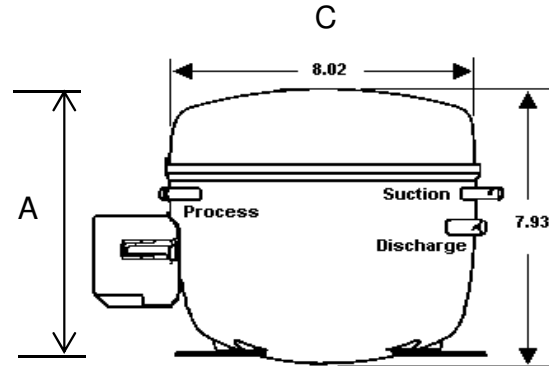

Tube Diameter

ID	Inch	MM
process	.256	6.5
suction	.323	8.2
discharge	.256	6.5

Technical Specifications

Rev 5-2013

Mechanical Data	English	Metric	Electrical Data	
Bore	0.93 in	24 mm	Motor: 2 pole - 1 phase	CSIR
Stroke	0.78 in	20 mm	Voltage	115v / 60 Hz
Displacement	0.552 cu in	9.04 cc	Voltage range	103-135V
Speed	3,500 rpm	3,500 rpm	Run winding resistance at 25° C	1.55 Ω
Weight	24.93 lb	11.31 kg	Start winding resistance at 25° C	4.15 Ω
Oil Charge	9.47 oz.	280 ml	Locked rotor current	35 Amps
Oil type	POE	ISO22	FLA: L/MBP-60Hz	5.7 amps
Compressor Cooling:			FLA: HBP-60Hz	6.6 amps
Fan cooled by forced draft over shell with 6 watt minimum fan.				
Restrictor:			Capacitor:	
Capillary Tube			Start Cap	270-324 mfd
Expansion valve			Run Cap	N/A

embraco	FF10HBX	LBP-MBP-HBP	115 V	134a
Specifications Approximate H. P. 1/4+ Starting Torque High Refrigerant 134a Evaporator Temperature Low/Med/High Evaporator Temperature -31° to 59°F			Usage Drinking Water Coolers Dehumidifiers Ice Machines Reach In Refrigerators Beer Coolers	

LBP Performance					
Temperature °F	-22	-10	5	14	23
Capacity BTU/Hr	556	840	1,371	1,745	2,189
Power W	200	217	286	322	361
Current Amps	3.92	3.86	4.29	4.47	4.69
Temperature °C	-30	-23.3	-15	-10	-5
Capacity Kcal/Hr	140	212	345	440	552
HBP Performance					
Temperature °F	14	23	32	45	50
Capacity BTU/Hr	1,745	2,189	2,715	3,650	4,061
Power W	322	361	403	464	490
Current Amps	4.47	4.69	4.94	5.25	5.54
Temperature °C	-10	-5	0	7.2	10
Capacity Kcal/Hr	440	552	684	920	1,023
LBP Rating	ASHRAE	Rating Point (bolded above)	HBP Rating	ASHRAE	
Condensing	130°F		Condensing	130°F	
Evaporator	-10°F		Evaporator	45°F	
Return Gas	90°F		Return Gas	95°F	
Ambient	90°F		Ambient	95°F	
Liquid Temp.	90°F		Liquid Temp.	115°F	

Material	Part number	Description	Compressor Cross Ref.	
Compressor	513200314	FF10HBX	Model	Appl.
Relay	513506009			
*Overload	13554609	MRT 20AGK-5590		
Start Cap	513556529	270-324 mfd / 165V		
Grommet	2221003			
Sleeve	2222015			
*Included in realy kit				

EMBRACO NORTH AMERICA, INC.
2800 Vista Ridge Dr. Suite 100, Suwanee Ga, 30024 Phone: 678-804-1337