



**FITTING YOUR NEEDS**

# **NDL Industries NBV-IN Insulation**



The NBV-IN Insulation is an EPDM-based, closed-cell, light-weight elastomeric thermal insulation specifically designed for solar and steam heating applications with service temperatures up to +150C (302F). Due to its unique design process, the NBV-IN Insulation embodies tough skin for easy installation. It is self-extinguished and does not melt when burnt. When using outdoors, the NBV-IN Insulation has excellent ozone, UV, and weather resistance properties but may need additional protective coating or jacketing for long term direct contact sunlight.

**866.635.6888 | [sales@ndlinc.com](mailto:sales@ndlinc.com) | [ndlinc.com](http://ndlinc.com)**



# NDL Industries NBV-IN Insulation

## NDL NBV-IN Specifications:

Properties		NDL-IN						Test Method
Cell Structure		Closed Cell						
Density lbs/ft <sup>3</sup> (Kg/m)		2.5-5.0 (40-80)						ASTM D1667
Thermal Conductivity BTU.In/Ft <sup>2</sup> hr °F (W/m.K)	Mean Temp	68°F (20°C)	104°F (40°C)	140°F (60°C)	176°F (80°C)	212°F (100°C)	303°F (150°C)	ASTM C 177 EN ISO 8497
	K-Value	0.250 (0.360)	0.263 (0.038)	0.277 (0.040)	0.284 (0.041)	0.306 (0.044)	0.395 (0.057)	
Service Temperature		Up to +150 °C Up to +302°F						ASTM C 411
Water Absorbtion		< 10% (by weight) < 0.20% (by volume)						ASTM D 1056 ASTM C209
Ozone Resistance		No Crack						ASTM E 1149 ASTM D 1171
UV Weather Resistance		Very Good						ASTM G 154
Flammability		Self-Extinguishing Class V-0						ASTM D 635 UL 94
RoHS		Not Detected						EN Restriction of the Use of Hazardous Substances Directive (RoHS) 2002/95/EC
Material		EPDM						
Working Temperature		-57°C to 125°C (-71°F to 257°F)						
UV Resistant Flame/Smoke Rating		15/50						
Color and Wall Thickness		Black, 3/4"						

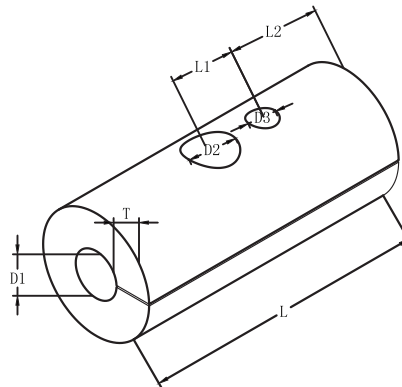

Parts No.	D1(mm)	D2(mm)	D3(mm)	L(mm)	L1(mm)	L2(mm)	Weight(g)
NBV-IN-S	25	15.00	26.00	153.00	32.00	70.00	28.50
NBV-IN-M	42	15.00	26.00	210.00	32.00	86.00	34.50
NBV-IN-R	42	15.00	26.00	170.00	32.00	86.00	32.00

NBV-IN-S:Compatible with 1/4 to 5/8 ball valves with schrader

NBV-IN-M:Compatible with 3/4 to 7/8 ball valves with schrader

NBV-IN-R:Compatible with all of NBVFFS and NBVFFS-NDL series

866.635.6888 | [sales@ndlinc.com](mailto:sales@ndlinc.com) | [ndlinc.com](http://ndlinc.com)

